Target Specification

Part number

SMLE12BC7T

Submission date

Date
25

Month
Apr

year
2007

Ms. T. Nakano

Product Planning Dept
LED Division

ROHM CO., LTD.

< Specifications (Precautions and Prohibitions) >

● **Safety Precautions**

1) The products are designed for application in ordinary electronic equipment (AV equipment, OA equipment, telecommunication equipment, home appliances, amusement equipment, etc.). If the products are to be used in devices requiring extremely high reliability (medical equipment, transport equipment, aircraft/spacecraft, nuclear power controllers, fuel controllers, car equipment including car accessories, safety devices, etc.) and whose malfunction or operational error may endanger human life, please consult with the Company's sales staff in advance. If product malfunctions may result in serious damage, including that to human life, sufficient fail-safe measures must be taken, including the following:

- [a] Installation of protection circuits or other protective devices to improve system safety
- [b] Installation of redundant circuits in the case of single-circuit failure

2) The products are designed for use in a standard environment and not in any special environments. Application of the products in a special environment can deteriorate product performance. Accordingly, verification and confirmation of product performance, prior to use, is recommended if used under the following conditions:

- [a] Use in various types of liquid, including water, oils, chemicals, and organic solvents
- [b] Use outdoors where the products are exposed to direct sunlight, or in dusty places
- [c] Use in places where the products are exposed to sea winds or corrosive gases, including Cl₂, H₂S, NH₃, SO₂, and NO₂
- [d] Use in places where the products are exposed to static electricity or electromagnetic waves
- [e] Use in proximity to heat-producing components, plastic cords, or other flammable items
- [f] Use involving sealing or coating the products with resin or other coating materials
- [g] Use involving unclean solder or use of water or water-soluble cleaning agents for cleaning after soldering
- [h] Use of the products in places subject to dew condensation

3) The products are not radiation resistant.

4) The Company is not responsible for any problems resulting from use of the products under conditions not recommended herein.

5) The Company should be notified of any product safety issues. Moreover, product safety issues should be periodically monitored by the customer.

● **Precautions Regarding Application Examples and External Circuits**

1) If change is made to the constant of an external circuit, allow a sufficient margin due to variations of the characteristics of the products and external components, including transient characteristics, as well as static characteristics.

2) The application examples, their constants, and other types of information contained herein are applicable only when the products are used in accordance with standard methods. Therefore, if mass production is intended, sufficient consideration to external conditions must be made.

DESIGN	CHECK	APPROVAL	DATE : Mar./ 1/2007	SPECIFICATION No. : —
J. Okada	H. Tada	S. Sakano	REV. : —	ROHM CO., LTD.

< Specifications (Precautions and Prohibitions) >

● **Precautions Regarding Foreign Exchange and Foreign Trade Control Law**

1) The Company has not determined whether or not the products are considered "a controlled product or labor" as specified in the Foreign Exchange and Foreign Trade Control Law.

Accordingly, if exportation of the products, either separately or integrated in another company's products, is interested, or giving the products to persons who are not residents is planned, additional steps are required, based upon the appropriate regulations.

● **Prohibitions Regarding Industrial Property**

1) These Specifications contain information related to the Company's industrial property. Any use of them other than pertaining to the usage of appropriate products is not permitted. Duplication of these Specifications and its disclosure to a third party without the Company's permission is prohibited.

2) Information and data on products, including application examples, contained in these specifications are simply for reference; the Company does not guarantee any industrial property rights, intellectual property rights, or any other rights of a third party regarding this information or data. Accordingly, the Company does not bear any responsibility for:

- [a] infringement of the intellectual property rights of a third party
- [b] any problems incurred by the use of the products listed herein.

3) The Company prohibits the purchaser of its products to exercise or use the intellectual property rights, industrial property rights, or any other rights that either belong to or are controlled by the Company, other than the right to use, sell, or dispose of the products.

● **Precautions on Use of Products**

1) Verification and confirmation of performance characteristics of products, after on-board mounting, is advised.

2) In particular, if a transient load (a large amount of load applied in a short period of time, such as pulse) is applied, confirmation of performance characteristics after on-board mounting is strongly recommended. Avoid applying power exceeding normal rated power; exceeding the power rating under steady-state loading condition may negatively affect product performance and reliability.

3) When a highly active halogenous (chlorine, bromine, etc.) flux is used, the remainder of flux may negatively affect product performance and reliability.

4) In principle, the reflow soldering method must be used; if flow soldering method is preferred, please consult with the Company in advance.

● **Precautions Regarding Product Storage**

1) Product performance and soldered connections may deteriorate if the products are stored in the following places:

- [a] Where the products are exposed to sea winds or corrosive gases, including Cl₂, H₂S, NH₃, SO₂, and NO₂
- [b] Where the temperature or humidity exceeds those recommended by the Company

2) The guaranteed period of solder connections and product performance is within one year from shipment by the Company, provided that the above-mentioned storage conditions have been satisfied.

● **Other Matters**

1) Please sign these Specifications and return one copy to the Company.

If a copy is not returned within three months after the issued date specified on the front page of these Specifications, the Company will consider the Specifications accepted.

2) If any matter related to these Specifications needs to be clarified, discussions shall be held promptly between the two parties concerned to determine the issue.

- 1. CONSTRUCTION InGaN on SiC blue surface mount LEDs with colorless epoxy.
- 2. USAGE Source of light for display unit.
- 3. DIMENSIONS See Figure.1
- 4. ABSOLUTE MAXIMUM RATINGS (Ta=25)

Power Dissipation	P D	66mW
Forward Current	I F	20mA
Peak Forward Current	I F P	100mA (Notes 1)
Reverse Voltage	V R	5V
Operating Temperature	Topr	- 30 ~ + 85
Storage Temperature	Tstg	- 40 ~ + 100

(Notes1 Duty 1/10 1kHz)

5. ELECTRO - CHARACTERISTICS (Ta=25)

DISCRIPTION	SYMBOL	CONDITION	MIN.	TYP.	MAX.	UNITS
Luminous Intensity	IV	IF=5mA	9.0	22	-	mcd
Forward Voltage	VF	IF=5mA	-	2.9	3.3	V
Reverse Current	IR	VR=5V	-	-	100	μ A
Peak Wave Length	P	IF=5mA	-	468	-	nm
Dominant Wave Length	D	IF=5mA	-	470	-	nm
Spectral Line Half Width		IF=10mA	-	26	-	nm

6. LUMINOUS CLASSIFICATION (Ta=25 , IF=5mA)

SYMBOL	LUMINOUS CLASSIFICATION RANGE
“M”	9 . 0 ~ 1 4 mcd
“N”	1 4 ~ 2 2 mcd
“P”	2 2 ~ 3 6 mcd
“Q”	3 6 ~ (5 6) mcd

If rank shift occur, we may ask for re-approval of new rank when necessary.

Measurement tolerance : ± 10%, () : Reference

- 7. PRODUCT WEIGHT Product weight per piece, approx 0.00093gm.

【Figure.1】

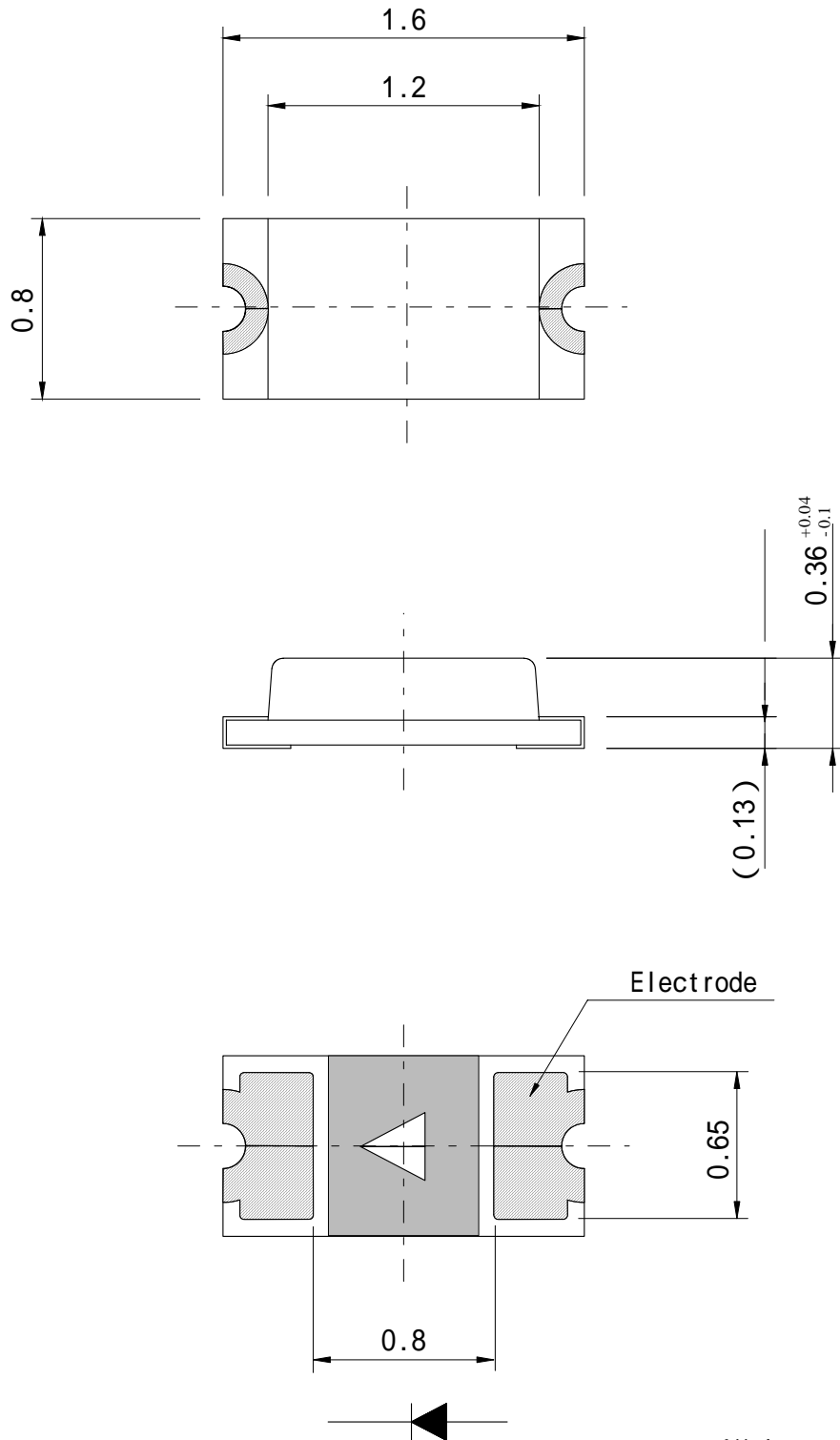

(Unit : mm)

(note) Tolerance is within ± 0.1 mm

unless otherwise specified

【T86】

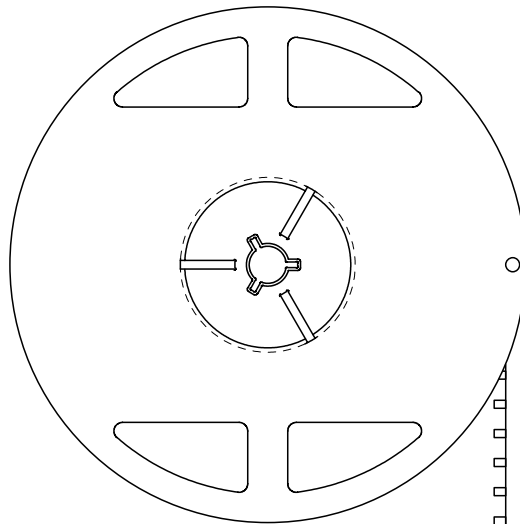
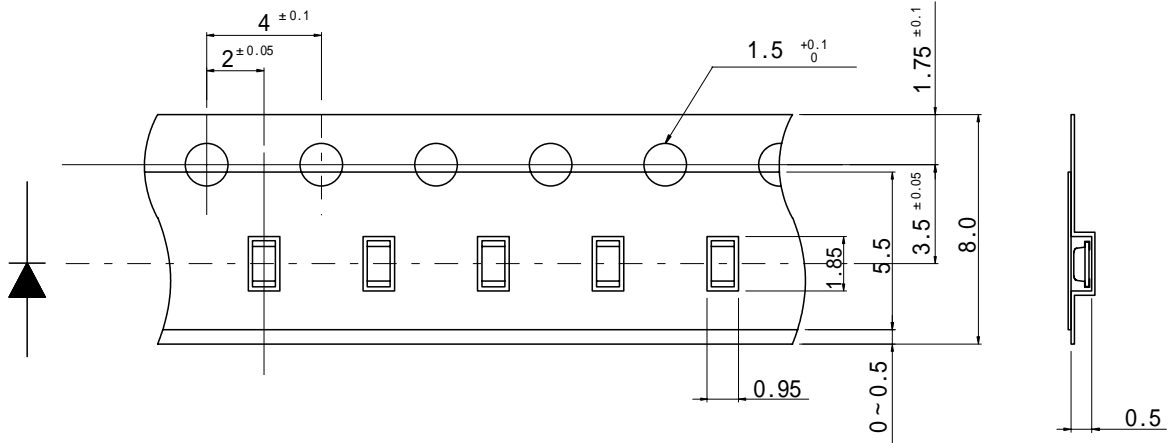

Packing quantity
5000pcs/reel

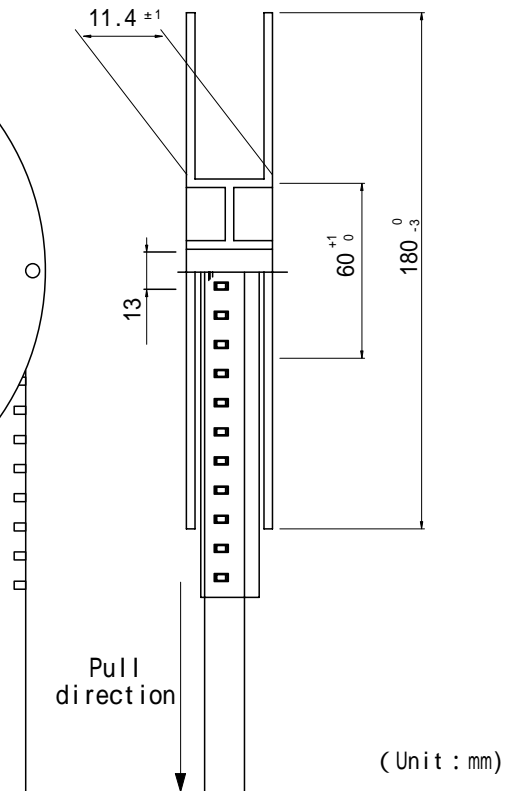

(Unit : mm)

(note) Tolerance is within ±0.2mm
unless otherwise specified

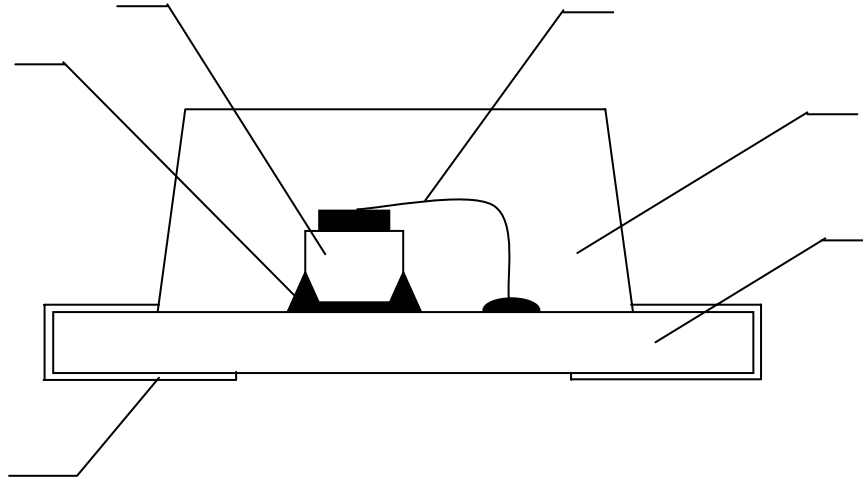
【STRUCTURE • MATERIAL】

No.	APPELLATION	MATERIAL
1	Printed Wiring Board	BT Resin, Glass Fabric
2	Die Bond	Ag Paste
3	Chip	InGaN on SiC
4	Bonding Wire	Gold
5	Resin	Epoxy Resin
6	Electrode	Bass plating : Cu , Nickel Top plating : Au

【PACKAGING REQUIREMENTS】

1. PACKING

- (1) 5,000pcs are packed in one reel.
- (2) One reel is packed in aluminum bag.
The size of aluminum bag is 240(a) × 250(b)mm.
The size up to 230(c)mm is to zipper.
- (3) Aluminum bag is sealed by pressured for all directions.

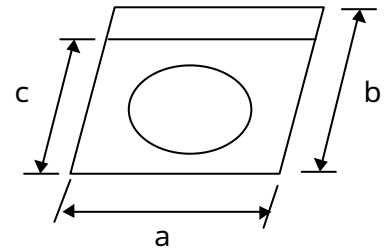

2. MARKING

The following information shall be described on a box label:
ROHM Type number, Packing quantity, Luminous intensity rank,
Lot number.

【FORMER LABEL SPECIFICATION】

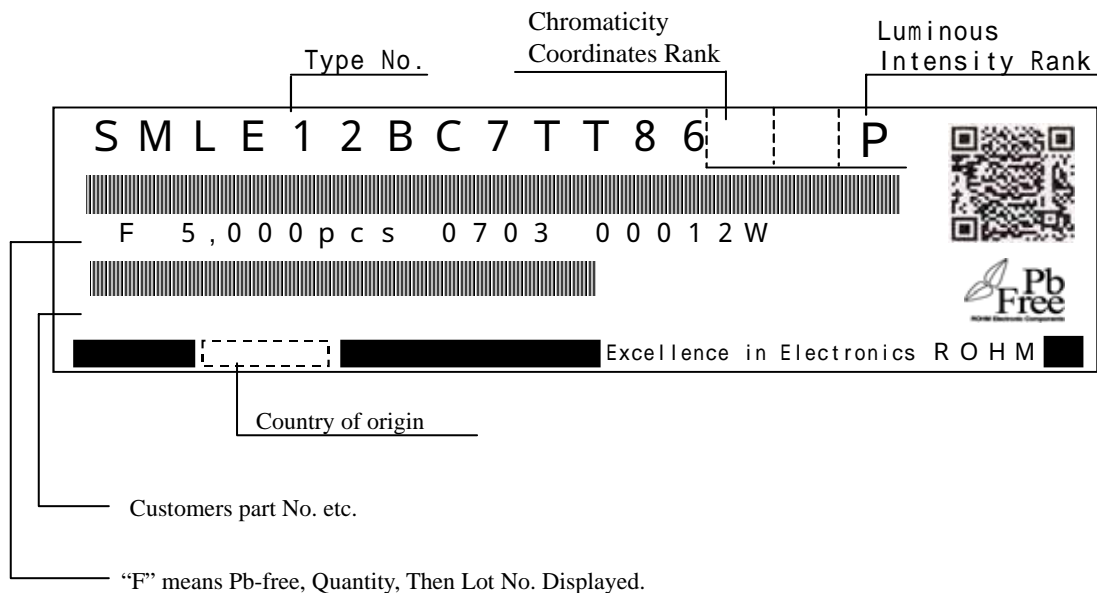

Note)  Indicates bar code expressed by code 39.

 indicates Pb-free Products.

【EXAMPLE OF LOT NO. MARKING】

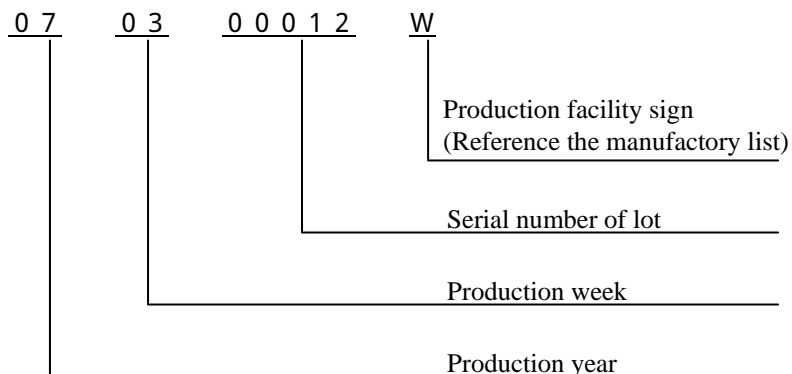

【ATTENTION POINT IN HANDLING】

This product was developed as a surface mount LED especially suitable for soldering. Please take care of following points when using this device.

1. DESIGNING OF PCB

As for a recommendable solder pattern, Please refer to Fig-1.
The size and direction of the pad pattern depends on the condition of the PCB,
So, please investigate about the adjustment thoroughly before designing.

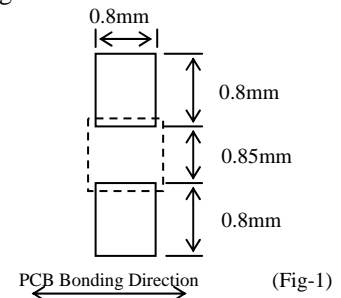

2. SOLDERING (Sn-Cu, Sn-Ag-Cu, Sn-Ag-Bi-Cu)

LED products do not contain reinforcement materials such as glass fillers. Therefore, thermal stress by soldering greatly influence its reliability. The temperature conditions for reflow soldering should therefore be set up according to the characteristic of this product. (See Fig-2)
Number of reflow process shall be max 2 times and these processes shall be performed in a row. Cooling process to normal temperature shall be required between first and second soldering process.

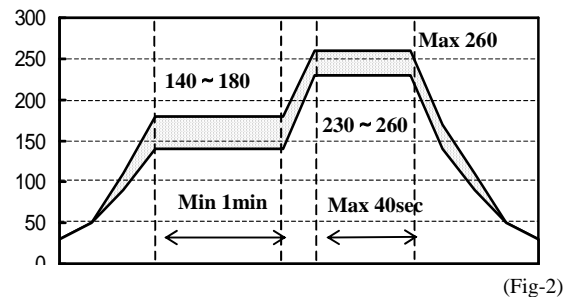

3. HANDLING AFTER MOUNTING

As shown right drawing, in case outside force of around 700g is given to the device, stress is concentrated to the jointed part between mold resin and substrate. Therefore there is a possibility to break the device or PCB. Careful handling is needed as ROHM cannot guarantee the falling of the device by outside force after mounting.

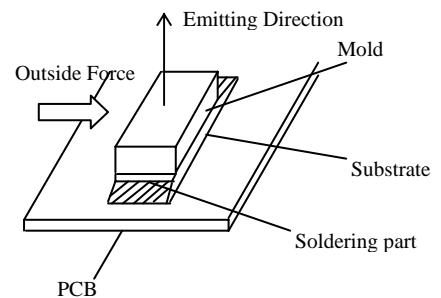

4. WASHING

Please note the following points when washing is required after soldering.

4-1) WASHING SOLVENT

Isopropyl alcohol or other alcohol solvent is recommendable.

4-2) TEMPERATURE

Below 30 °C, immersion time ; within 3 minutes.

4-3) ULTRA SONIC WASHING

Below 15 / 1 liter of solvent tub.

4-4) COOLING

Below 100 °C within 3 minutes.

5. STORAGE

At reflow soldering, the reliability of this product is often influenced by moisture absorption so we apply the packaging with moisture proof for better condition is use, please also note that

5-1) Not to be opened before using.

5-2) To be kept in our moisture proof packaging with some desiccant (SILICA GEL) after opening it.

To be baked in case the SILICA GEL indicator loses its blue color.

5-3) Please use within 168 hours after the package was opened. (Condition at 30 °C, max.70%Rh.)

In case it is not used within 168 hours, please put it back into our packaging.

5-4) BAKING

Please bake under reel condition at 60 °C, 12 ~ 24 hours (max.20%Rh) after un-sealing.

While baking is done, the reel and emboss tape may be easily deformed.

Please be careful not to give any stress.